

## Product Feature

- Suitable for ultra-pure, flammable or toxic fluid lines in semiconductor manufacturing equipment and facilities
- Direct diaphragm construction with superior sealing performance, remarkable durability, compactness and particle and dead-space-free performance
- Valve open and closed position is easily visible at a glance
- Excellent gas displacement characteristics
- EP treatment is standard for all wetted surfaces
- Standard seat material is PCTFE, Polyimide / PFA is option

## Temperature / Pressure Rating

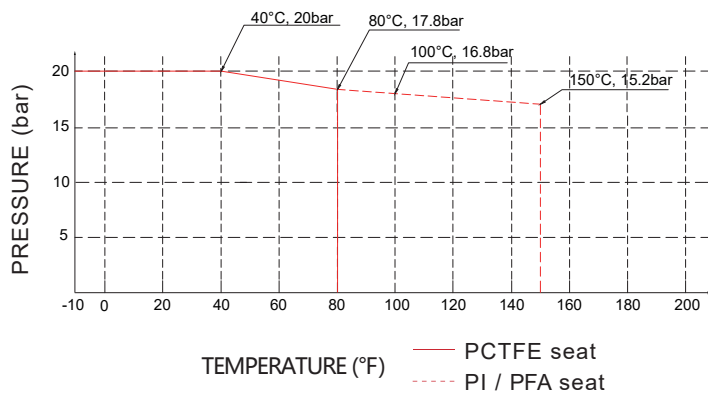

1/4 Type



1/4 Type



1/2 Type



1/2 Type

## Technical Data

Max. Working Pressure:	300 psig (20bar)
Actuation Pressure:	58~87psig (4~6bar)
Max. Working Temp.:	14°F ~ 176°F (-10°C ~ 80°C)
Surface finish:	10µin. Ra
<b>Materials</b>	
Body:	see ordering info
Diaphragm:	Elgiloy®
Seat packing:	PCTFE
Handle:	AL
Internal Leakage Allowance:	1x10 <sup>-9</sup> mbar-l/s He
External Leakage Allowance:	1x10 <sup>-9</sup> mbar-l/s He
Flow capacity:	1/4" Cv=0.3    3/8" 1/2" Cv=0.65
Weight:	approx. 0.27kg (depending on connections or options)



## Dimensions (mm)

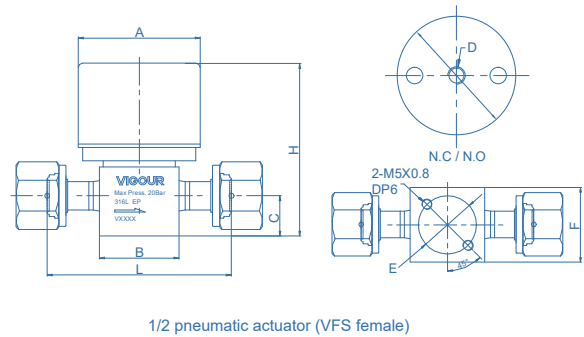
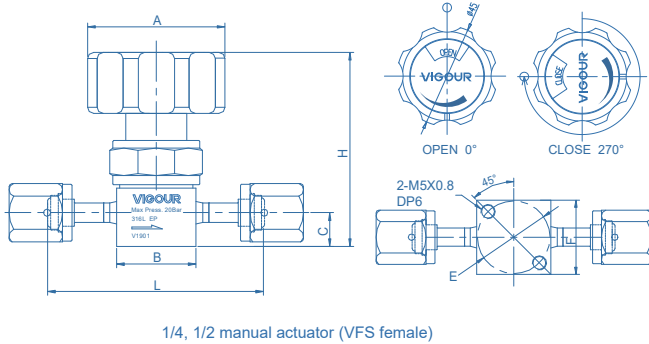
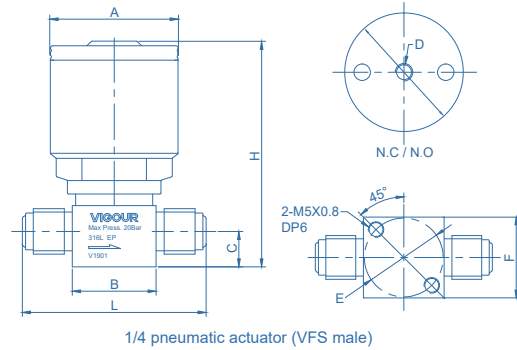
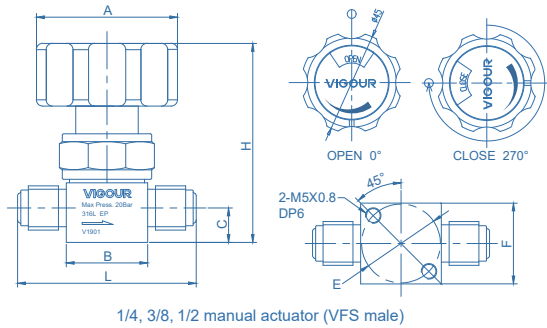

### manual actuator

End Connections	Orifice (mm)	Dimensions (mm)						
		A	B	C	E	F	L	H
1/4" VFS male	4.4	Φ45	26	11	Φ25.4	26	57	64
1/4" VFS female	4.4	Φ45	26	11	Φ25.4	26	71	64
3/8" VFS male	7	Φ45	36	18.2	Φ28	36	77	78
1/2" VFS male	7	Φ45	36	18.2	Φ28	36	77	78
1/2" VFS female	7	Φ45	36	18.2	Φ28	36	83	78

### pneumatic actuator, normally opened / normally closed

End Connections	Actuator	Orifice (mm)	Dimensions (mm)							
			A	B	C	D	E	F	L	H
1/4" VFS male	N.C / N.O.	4.4	Φ39.6	26	11	M5x0.8	Φ25.4	26	57	70
1/4" VFS female	N.C / N.O.	4.4	Φ39.6	26	11	M5x0.8	Φ25.4	26	71	70
3/8" VFS male	N.C / N.O.	7	Φ55	36	18.2	RC 1/8	Φ28	36	77	78
1/2" VFS male	N.C / N.O.	7	Φ55	36	18.2	RC 1/8	Φ28	36	77	78
1/2" VFS female	N.C / N.O.	7	Φ55	36	18.2	RC 1/8	Φ28	36	83	78

## Ordering information

**VDV52UBS - M - A - MV4 - MV4 - PA - P**

### Materials

S: 316L

### Actuator

M: manual actuator

PO: pneumatic actuator, normally opened

PC: pneumatic actuator, normally closed

### Flow Circuit Diagram

For details, refer to the flow circuit diagram on page 67.

### End Connection

MV4: 1/4" VFS male

FV4: 1/4" VFS female

TW4: 1/4" tube weld

MV6: 1/2" VFS male 3/8" O.D.

FV6: 1/2" VFS female 3/8" O.D.

TW6: 3/8" tube weld

MV8: 1/2" VFS male

FV8: 1/2" VFS female

TW8: 1/2" tube weld

### Process Specification

none: VS001B

P: VS001A

\* For details, please refer to the appendix.

### Valve Seat Option

None: PCTFE (standard)

VS: Vespel®

PA: PFA

\* Other connection standard, consult factory



## Product Feature

- Suitable for ultra-pure, flammable or toxic fluid lines in semiconductor manufacturing equipment and facilities
- Direct diaphragm construction with superior sealing performance, remarkable durability, compactness and particle and dead-space-free performance
- Valve open and closed position is easily visible at a glance
- Excellent gas displacement characteristics
- EP treatment is standard for all wetted surfaces
- Standard seat material is PCTFE, Polyimide / PFA is option

## Temperature / Pressure Rating

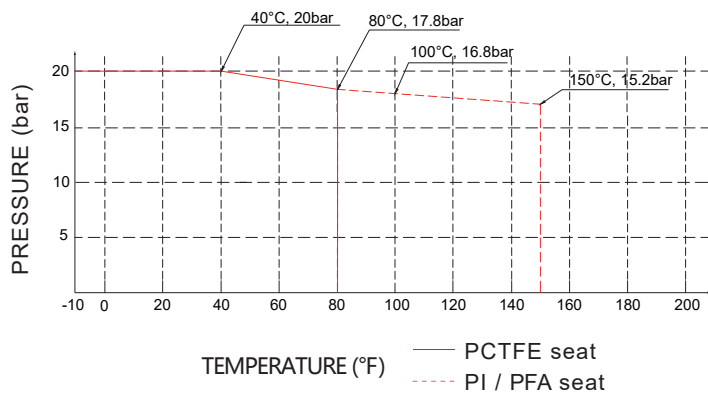

1/4 Type



1/4 Type



1/2 Type



1/2 Type

## Technical Data

Max. Working Pressure:	300 psig (20bar)
Actuation Pressure:	58~87psig (4~6bar)
Max. Working Temp.:	14°F ~ 176°F (-10°C ~ 80°C)
Surface finish:	7µin. Ra
Materials	
Body:	see ordering info
Diaphragm:	Elgiloy®
Seat packing:	PCTFE
Handle:	AL
Internal Leakage Allowance:	1x10 <sup>-9</sup> mbar-l/s He
External Leakage Allowance:	1x10 <sup>-9</sup> mbar-l/s He
Flow capacity:	1/4" Cv=0.3    3/8" 1/2" Cv=0.65
Weight:	approx. 0.27kg (depending on connections or options)



## Dimensions (mm)

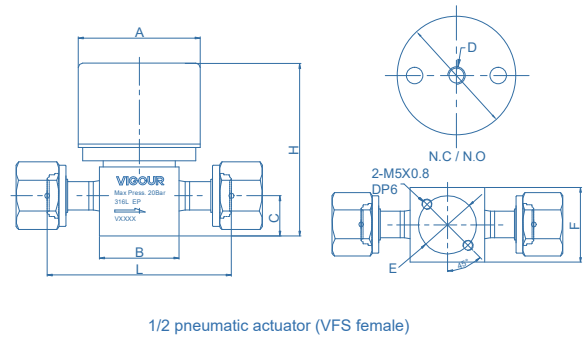
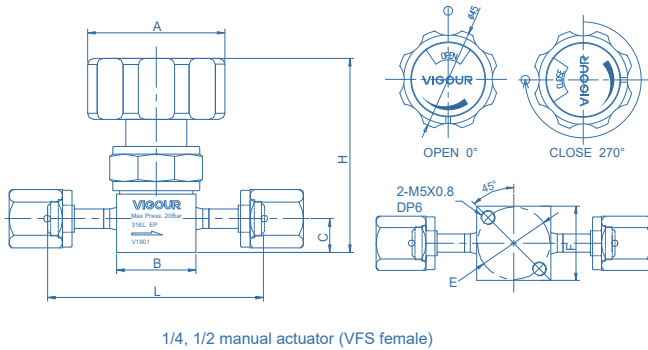
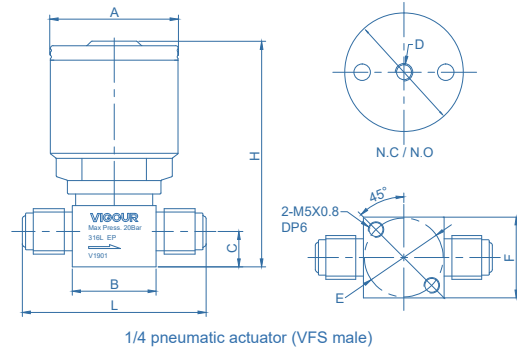
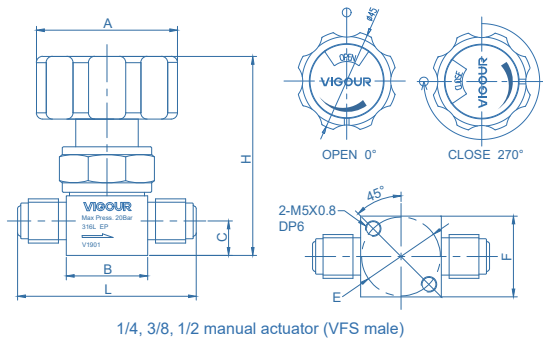

### manual actuator

End Connections	Orifice (mm)	Dimensions (mm)						
		A	B	C	E	F	L	H
1/4" VFS male	4.4	Φ45	26	11	Φ25.4	26	57	64
1/4" VFS female	4.4	Φ45	26	11	Φ25.4	26	71	64
3/8" VFS male	7	Φ45	36	18.2	Φ28	36	77	78
1/2" VFS male	7	Φ45	36	18.2	Φ28	36	77	78
1/2" VFS female	7	Φ45	36	18.2	Φ28	36	83	78

### pneumatic actuator, normally opened / normally closed

End Connections	Actuator	Orifice (mm)	Dimensions (mm)							
			A	B	C	D	E	F	L	H
1/4" VFS male	N.C / N.O	4.4	Φ39.6	26	11	M5x0.8	Φ25.4	26	57	70
1/4" VFS female	N.C / N.O	4.4	Φ39.6	26	11	M5x0.8	Φ25.4	26	71	70
3/8" VFS male	N.C / N.O	7	Φ55	36	18.2	RC 1/8	Φ28	36	77	78
1/2" VFS male	N.C / N.O	7	Φ55	36	18.2	RC 1/8	Φ28	36	77	78
1/2" VFS female	N.C / N.O	7	Φ55	36	18.2	RC 1/8	Φ28	36	83	78

## Ordering information

**VDV52UCSLV - M - A - MV4 - MV4 - PA - P**

### Materials

SLV: 316L secondary remelt

### Actuator

M: manual actuator  
 PO: pneumatic actuator, normally opened  
 PC: pneumatic actuator, normally closed

### Flow Circuit Diagram

For details, refer to the flow circuit diagram on page 67.

### Process Specification

P: VS001A

\* For details, please refer to the appendix.

### Valve Seat Option

None: PCTFE (standard)  
 VS: Vespel®  
 PA: PFA

### End Connection

MV4: 1/4" VFS male  
 FV4: 1/4" VFS female  
 TW4: 1/4" tube weld  
 MV6: 1/2" VFS male 3/8" O.D.  
 FV6: 1/2" VFS female 3/8" O.D.  
 TW6: 3/8" tube weld  
 MV8: 1/2" VFS male  
 FV8: 1/2" VFS female  
 TW8: 1/2" tube weld

\* Other connection standard, consult factory



# Diaphragm Valve Flow Circuit Diagram

## Ports Diagrammatic Drawing:

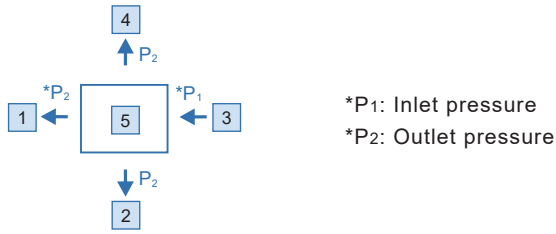

## Two ports flow circuit diagram:

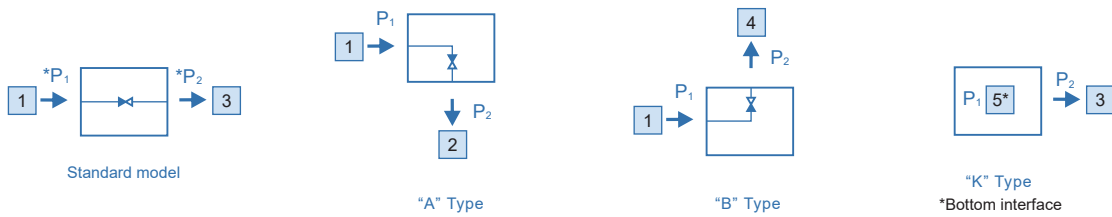

## Three ports flow circuit diagram:

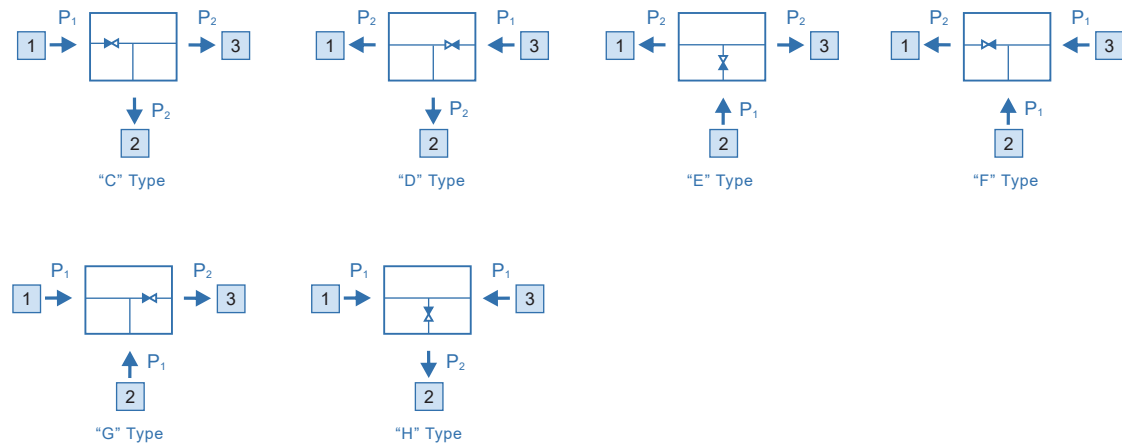

## Four ports flow circuit diagram:

