

## Product Feature

- Suitable for ultra-pure, flammable or toxic fluid lines in semiconductor manufacturing equipment and facilities
- Direct diaphragm construction with superior sealing performance, remarkable durability, compactness and particle free performance
- The product is fabricated in compliance with the VS001A process specification
- Valve open and closed position is easily visible at a glance
- Excellent gas displacement characteristics
- EP treatment is standard for all wetted surfaces
- Standard seat material is PCTFE, Polyimide is option

## Temperature / Pressure Rating

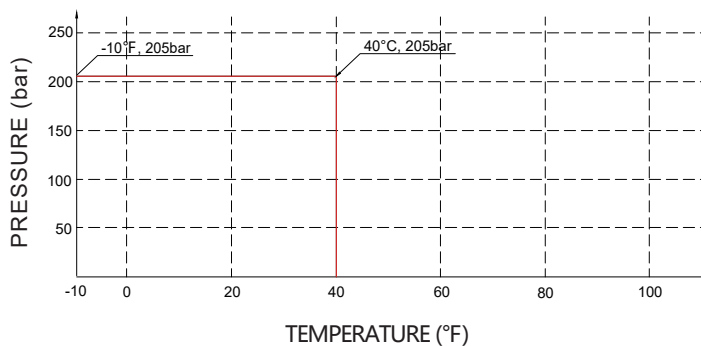

1/4" pneumatic actuator



1/4" manual actuator



1/4" Right-angle handle



1/4" manual actuator (Lockable)

## Technical Data

Max. Working Pressure:	3000 psig (200bar)
Actuation Pressure:	70~110 psig (5~8bar)
Max. Working Temp.:	-40°F ~ 160°F (-40°C ~ 71°C)
Surface finish:	10µin. Ra
Materials	
Body:	see ordering info
Diaphragm:	Elgiloy®
Seat packing:	PCTFE
Handle:	AL
Internal Leakage Allowance:	1x10 <sup>-9</sup> mbar·l/s He
External Leakage Allowance:	1x10 <sup>-9</sup> mbar·l/s He
Flow capacity:	pneumatic actuator Cv=0.23    manual actuator Cv=0.29
Weight:	approx 1.27kg (depending on connections or options)



## Dimensions (mm)

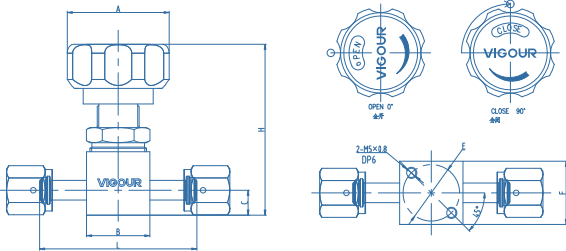

manual actuator

End Connections	Orifice (mm)	Dimensions (mm)						
		A	B	C	E	F	L	H
1/4" VFS male	4.4	Φ47.5	28.4	11.2	Φ25.4	28.4	70.6	77
1/4" VFS female	4.4	Φ47.5	28.4	11.2	Φ25.4	28.4	70.6	77
3/8" VFS male	4.4	Φ47.5	28.4	11.2	Φ25.4	28.4	98	77
3/8" VFS female	4.4	Φ47.5	28.4	11.2	Φ25.4	28.4	98	77
1/4" Tube weld	4.4	Φ47.5	28.4	11.2	Φ25.4	28.4	53.8	77
3/8" Tube weld	4.4	Φ47.5	28.4	11.2	Φ25.4	28.4	67.4	77

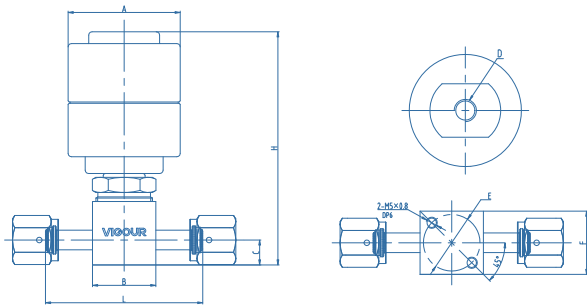

pneumatic actuator (normally closed)

End Connections	Orifice (mm)	Dimensions (mm)							
		A	B	C	D	E	F	L	H
1/4" VFS male	4.4	Φ50.3	28.4	11.2	M5x0.8	Φ25.4	28.4	70.6	105
1/4" VFS female	4.4	Φ50.3	28.4	11.2	M5x0.8	Φ25.4	28.4	70.6	105
3/8" VFS male	4.4	Φ50.3	28.4	11.2	M5x0.8	Φ25.4	28.4	98	105
3/8" VFS female	4.4	Φ50.3	28.4	11.2	M5x0.8	Φ25.4	28.4	98	105
1/4" Tube weld	4.4	Φ50.3	28.4	11.2	M5x0.8	Φ25.4	28.4	53.8	105
3/8" Tube weld	4.4	Φ50.3	28.4	11.2	M5x0.8	Φ25.4	28.4	67.4	105

## Ordering Information

### VDV40UBS - M - A - MV4 - MV4 - VS - LO - P

#### Materials

S: 316L

#### Actuator

M: manual actuator

PC: pneumatic actuator (normally closed)

#### Flow Circuit Diagram

For details, refer to the flow circuit diagram on page 67.

#### End Connection

MV4: 1/4" VFS male

FV4: 1/4" VFS female

TW4: 1/4" tube weld

MV6: 1/2" VFS male 3/8" O.D.

FV6: 1/2" VFS female 3/8" O.D.

TW6: 3/8" tube weld

\* Other connection standard, consult factory

#### Process Specification

None: VS001B

P: VS001A

\* For details, please refer to the appendix..

#### Optional

None: Round Knob

LO: Round Knob

Pull, then turn to open  
lock out / tag out

L: Right-angle handle

#### Valve Seat Option

None: PCTFE (standard)

VS: Vespel®



## Product Feature

- Suitable for ultra-pure, flammable or toxic fluid lines in semiconductor manufacturing equipment and facilities
- Direct diaphragm construction with superior sealing performance, remarkable durability, compactness and particle free performance
- Valve open and closed position is easily visible at a glance
- Excellent gas displacement characteristics
- EP treatment is standard for all wetted surfaces
- Standard seat material is PCTFE, Polyimide is option

## Temperature / Pressure Rating

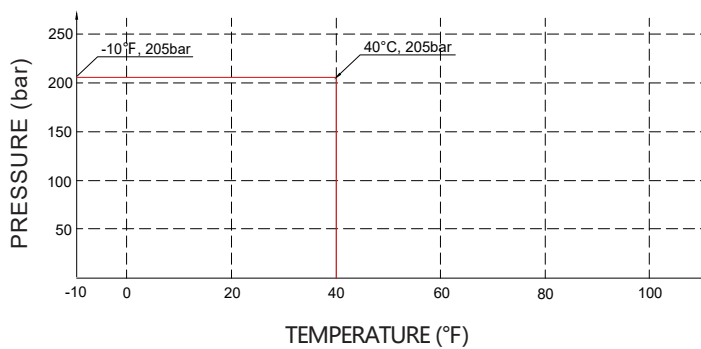

1/4" pneumatic actuator



1/4" manual actuator



1/4" Right-angle handle



1/4" manual actuator (Lockable)

## Technical Data

Max. Working Pressure:	3000 psig (200bar)
Actuation Pressure:	70~110 psig (5~8bar)
Max. Working Temp.:	-40°F ~ 160°F (-40°C ~ 71°C)
Surface finish:	7µin. Ra
<b>Materials</b>	
Body:	see ordering info
Diaphragm:	Elgiloy®
Seat packing:	PCTFE
Handle:	AL
Internal Leakage Allowance:	1x10 <sup>-9</sup> mbar·l/s He
External Leakage Allowance:	1x10 <sup>-9</sup> mbar·l/s He
Flow capacity:	pneumatic actuator Cv=0.23    manual actuator Cv=0.29
Weight:	approx 1.27kg (depending on connections or options)



## Dimensions (mm)

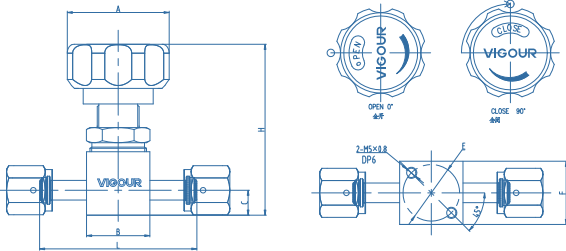

manual actuator

End Connections	Orifice (mm)	Dimensions (mm)						
		A	B	C	E	F	L	H
1/4" VFS male	4.4	Φ47.5	28.4	11.2	Φ25.4	28.4	70.6	77
1/4" VFS female	4.4	Φ47.5	28.4	11.2	Φ25.4	28.4	70.6	77
3/8" VFS male	4.4	Φ47.5	28.4	11.2	Φ25.4	28.4	98	77
3/8" VFS female	4.4	Φ47.5	28.4	11.2	Φ25.4	28.4	98	77
1/4" Tube weld	4.4	Φ47.5	28.4	11.2	Φ25.4	28.4	53.8	77
3/8" Tube weld	4.4	Φ47.5	28.4	11.2	Φ25.4	28.4	67.4	77

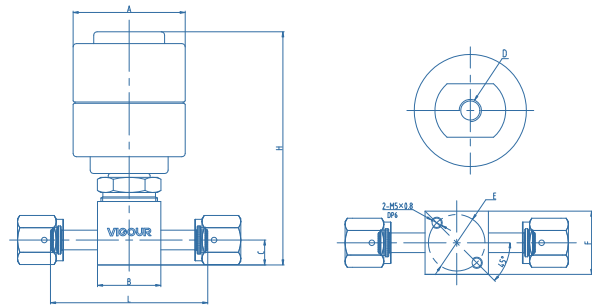

pneumatic actuator (normally closed)

End Connections	Orifice (mm)	Dimensions (mm)							
		A	B	C	D	E	F	L	H
1/4" VFS male	4.4	Φ50.3	28.4	11.2	M5x0.8	Φ25.4	28.4	70.6	105
1/4" VFS female	4.4	Φ50.3	28.4	11.2	M5x0.8	Φ25.4	28.4	70.6	105
3/8" VFS male	4.4	Φ50.3	28.4	11.2	M5x0.8	Φ25.4	28.4	98	105
3/8" VFS female	4.4	Φ50.3	28.4	11.2	M5x0.8	Φ25.4	28.4	98	105
1/4" Tube weld	4.4	Φ50.3	28.4	11.2	M5x0.8	Φ25.4	28.4	53.8	105
3/8" Tube weld	4.4	Φ50.3	28.4	11.2	M5x0.8	Φ25.4	28.4	67.4	105

## Ordering Information

### VDV40UCSLV - M - A - MV4 - MV4 - VS - LO - P

#### Materials

SLV: 316L secondary remelt

#### Actuator

M: manual actuator  
PC: pneumatic actuator (normally closed)

#### Flow Circuit Diagram

For details, refer to the flow circuit diagram on page 67.

#### End Connection

MV4: 1/4" VFS male  
FV4: 1/4" VFS female  
TW4: 1/4" tube weld  
MV6: 1/2" VFS male 3/8" O.D.  
FV6: 1/2" VFS female 3/8" O.D.  
TW6: 3/8" tube weld

\* Other connection standard, consult factory

#### Process Specification

P: VS001A

\* For details, please refer to the appendix..

#### Optional

None: Round Knob  
LO: Round Knob  
Pull, then turn to open  
lock out / tag out  
L: Right-angle handle

#### Valve Seat Option

None: PCTFE (standard)  
VS: Vespel®



# Diaphragm Valve Flow Circuit Diagram

## Ports Diagrammatic Drawing:

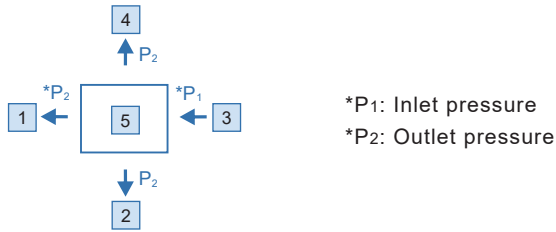

## Two ports flow circuit diagram:

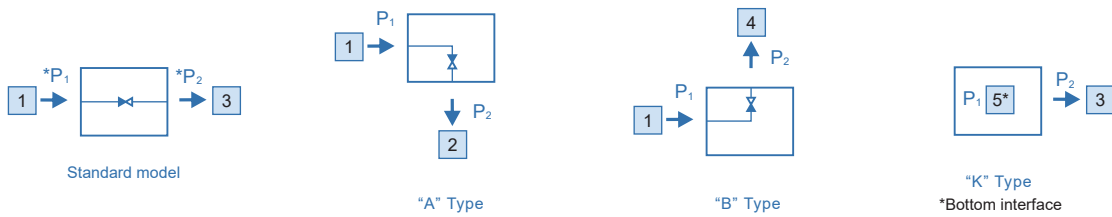

## Three ports flow circuit diagram:

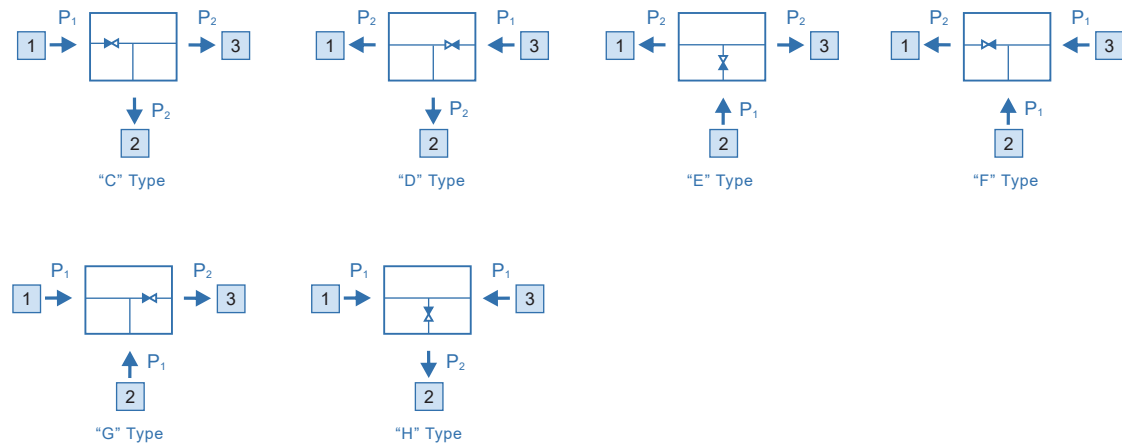

## Four ports flow circuit diagram:

