

# Pressure Control Panel

## VSP-1E Series

VIGOUR

### Product Features

- Manual pressure control panel
- VSR-1E / VSR-6E Series single-stage regulator
- Brass chrome plated body for inert, reactive, flammable and oxidizing gas and mixtures up to grade 6.0
- Stainless steel 316L body for corrosive gases
- Modular design
- Diaphragm type shut-off valves
- Suitable for inlet pressure up to 300 bar
- Easy installation into safety cabinet for gas cylinders



### Typical Applications

- Component Testing
- Calibration Systems
- Laboratory Pressure Control
- High Pressure Sampling Systems
- Service & Test Equipment

### Technical Data

Type:	single-stage
Inlet pressure P1:	max. 300 bar
Outlet pressure P2:	2/4/10/15/20/50/100/200 bar
Materials	
Body regulator:	see ordering info
Valve seat (regulator):	PCTFE
(shut-off valve):	PCTFE
Diaphragm (regulator):	Hastelloy®C276
(valve):	Elgiloy®
O-ring:	Viton® (FKM)
(option)	Kalrez® (FFKM)
Filter:	SS 316L
Inlet connection:	1/4"NPT(F)
Outlet connection:	1/4"NPT(F)
Temperature range:	-30°C to +74°C
Leak rate (to atmosphere):	1x10 <sup>-8</sup> mbar l/s He
(via seat):	1x10 <sup>-6</sup> mbar l/s He
Flow capacity:	Cv=0.07
Weight:	3.3kg

### Schematic Drawing

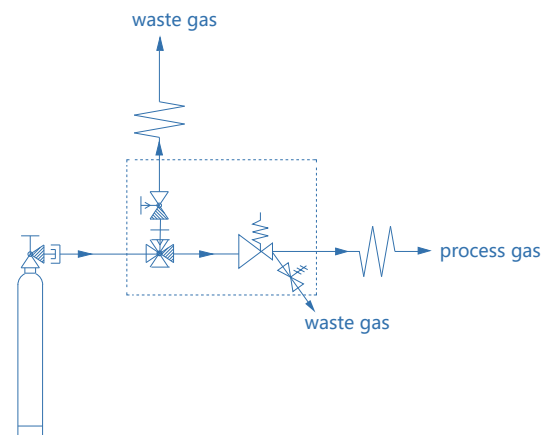

### Flow Chart

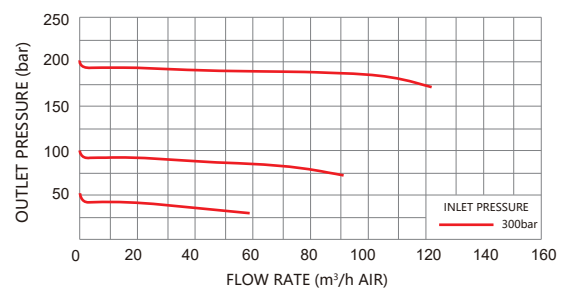
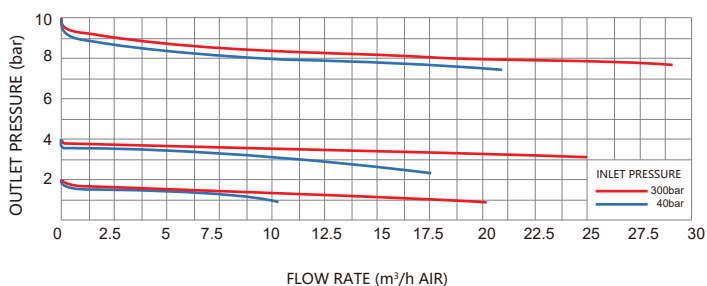

### Dimensions (mm)

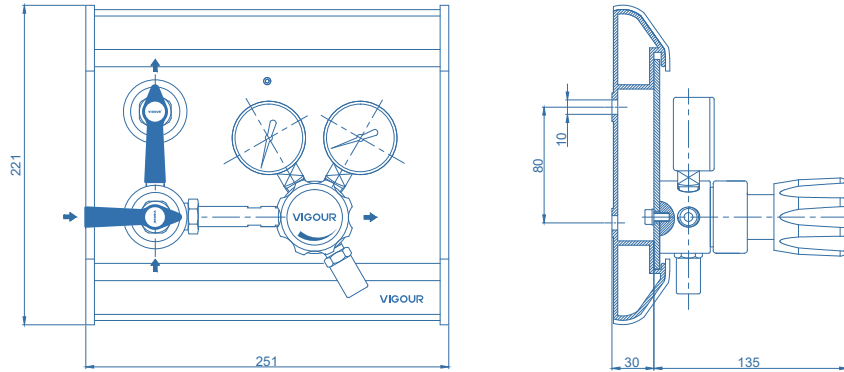

### Ordering Information

**VSP - 1ES - 300 - 10 - P - P - V - N<sub>2</sub>**

**Body Material**

S: 316L

C: Chrome Plated Brass

**Inlet Pressure P<sub>1</sub>**

40: 40 bar

100: 100 bar

200: 200 bar

300: 300 bar

**Outlet Pressure P<sub>2</sub>**

2: to 2 bar

4: to 4 bar

10: to 10 bar

15: to 15 bar

20: to 20 bar

50: to 50 bar (Non Relief valve)

100: to 100 bar (Non Relief valve)

200: to 200 bar (Non Relief valve)

**Type Of Gas**

Please specify type of gas

**Option**

Blank: Includes inlet valve and vent valve

V: Including inlet valve, not including vent valve

**Outlet Pressure Indication**

P: Pressure gauge

K: Contact gauge

**Inlet Pressure Indication**

P: Pressure gauge

K: Contact gauge

