

Pressure Control Panel

VSP-2 Series

VIGOUR

Product Features

- Semi-automatic pressure control panel
- VSR-2E Series single-stage regulator
- Brass chrome plated body for inert, reactive, flammable and oxidizing gas and mixtures up to grade 6.0
- Stainless steel 316L body for corrosive gases
- Modular design
- Diaphragm type shut-off valves
- Suitable for inlet pressure up to 300 bar
- Easy installation into safety cabinet for gas cylinders



Typical Applications

- Component Testing
- Calibration Systems
- Laboratory Pressure Control
- High Pressure Sampling Systems
- Service & Test Equipment

Technical Data

Type:	single-stage
Inlet pressure P1:	max. 300 bar
Outlet pressure P2:	2/4/10/20/35/50 bar
Materials	
Body regulator:	see ordering info
Valve seat (regulator):	PCTFE
(shut-off valve):	PCTFE
Diaphragm (regulator):	Hastelloy®C276
(valve):	Elgiloy®
O-ring:	Viton® (FKM)
(option)	Kalrez® (FFKM)
Filter:	SS 316L
Inlet connection:	1/4"NPT(F)
Outlet connection:	1/4"NPT(F)
Temperature range:	-30°C to +74°C
Leak rate (to atmosphere):	1x10 ⁻⁸ mbar l/s He
(via seat):	1x10 ⁻⁶ mbar l/s He
Flow capacity:	Cv=0.08
Weight:	4.5kg

Schematic Drawing

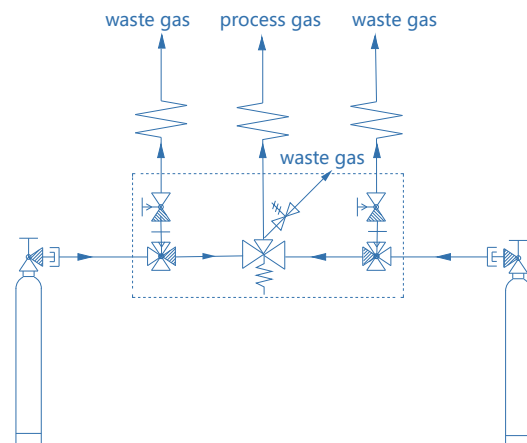

Flow Chart

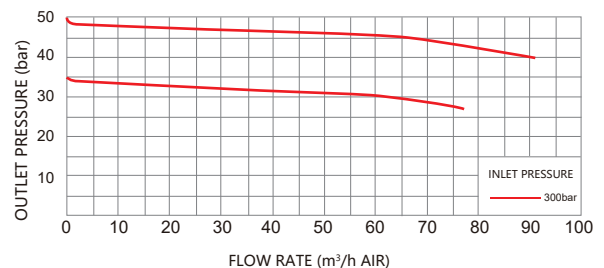
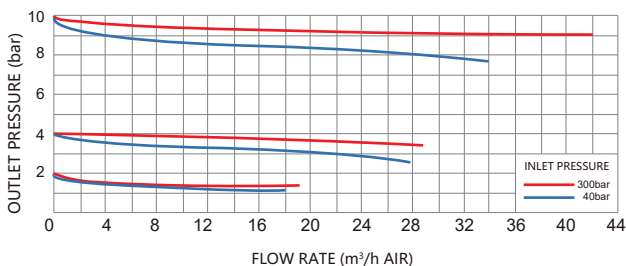

Dimensions (mm)

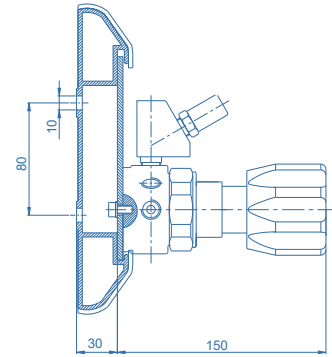
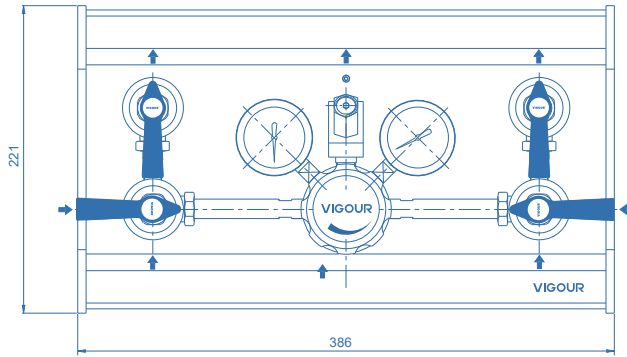

Ordering Information

VSP - 2S - 300 - 10 - P - P - V - N₂

<p>Body Material</p> <p>S: 316L</p> <p>C: Chrome Plated Brass</p>	<p>Inlet Pressure P₁</p> <p>40: 40 bar</p> <p>100: 100 bar</p> <p>200: 200 bar</p> <p>300: 300 bar</p>	<p>Outlet Pressure P₂</p> <p>2: to 2 bar</p> <p>4: to 4 bar</p> <p>10: to 10 bar</p> <p>20: to 20 bar</p> <p>35: to 35 bar (Non Relief valve)</p> <p>50: to 50 bar (Non Relief valve)</p>	<p>Type Of Gas</p> <p>Please specify type of gas</p>	<p>Option</p> <p>None: Includes inlet valve and vent valve</p> <p>V: Including inlet valve, not including vent valve</p>	<p>Outlet Pressure Indication</p> <p>P: Pressure gauge</p> <p>K: Contact gauge</p>	<p>Inlet Pressure Indication</p> <p>P: Pressure gauge</p> <p>K: Contact gauge</p>
--	--	---	---	---	---	--

